



COVAL

vacuum managers

mini-modules
compact integrated vacuum pumps

LEM



ARSaving
Regulator

LEM Series: Mini-Module



AR Saving Regulator

40% energy savings
(on average, see p.5).

→ No more unnecessary consumption of compressed air.



certified quality management system

twin
tech
TM

Integration & Intelligence

All industrial vacuum functions integrated into the mini-module

Efficient communication for easy setting, production and maintenance.

Vacuum Pumps

A mini-module for each application:

A COMPLETE LINE

- 4 basic configurations, see adjacent illustrations →
- 2 levels : 60% and 85% vacuum.
- 3 standard nozzle diameters : 1, 1.2 and 1.4 mm.
- Air suction flow : up to 92 NI/min.
- Other options on request.



EFFICIENT COMMUNICATION

For settings and troubleshooting, a simple and complete interface provides reliable communication as shown in the illustration.

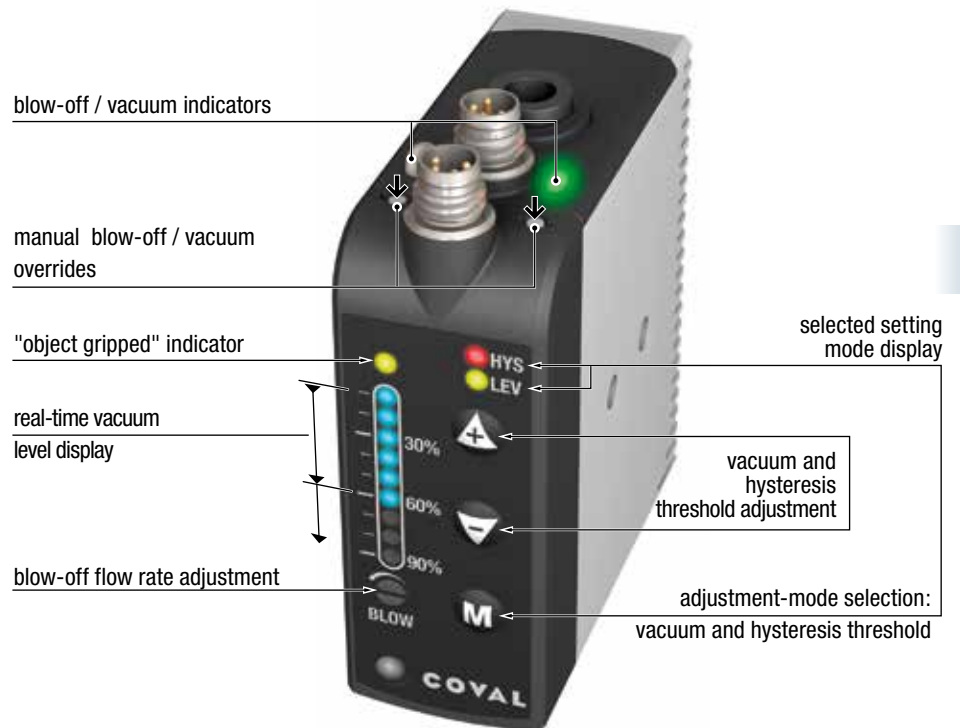

MOUNTING OPTIONS

Individual mountings, close to vacuum cups or compact island assembly.



LEM Series: Compact Functions

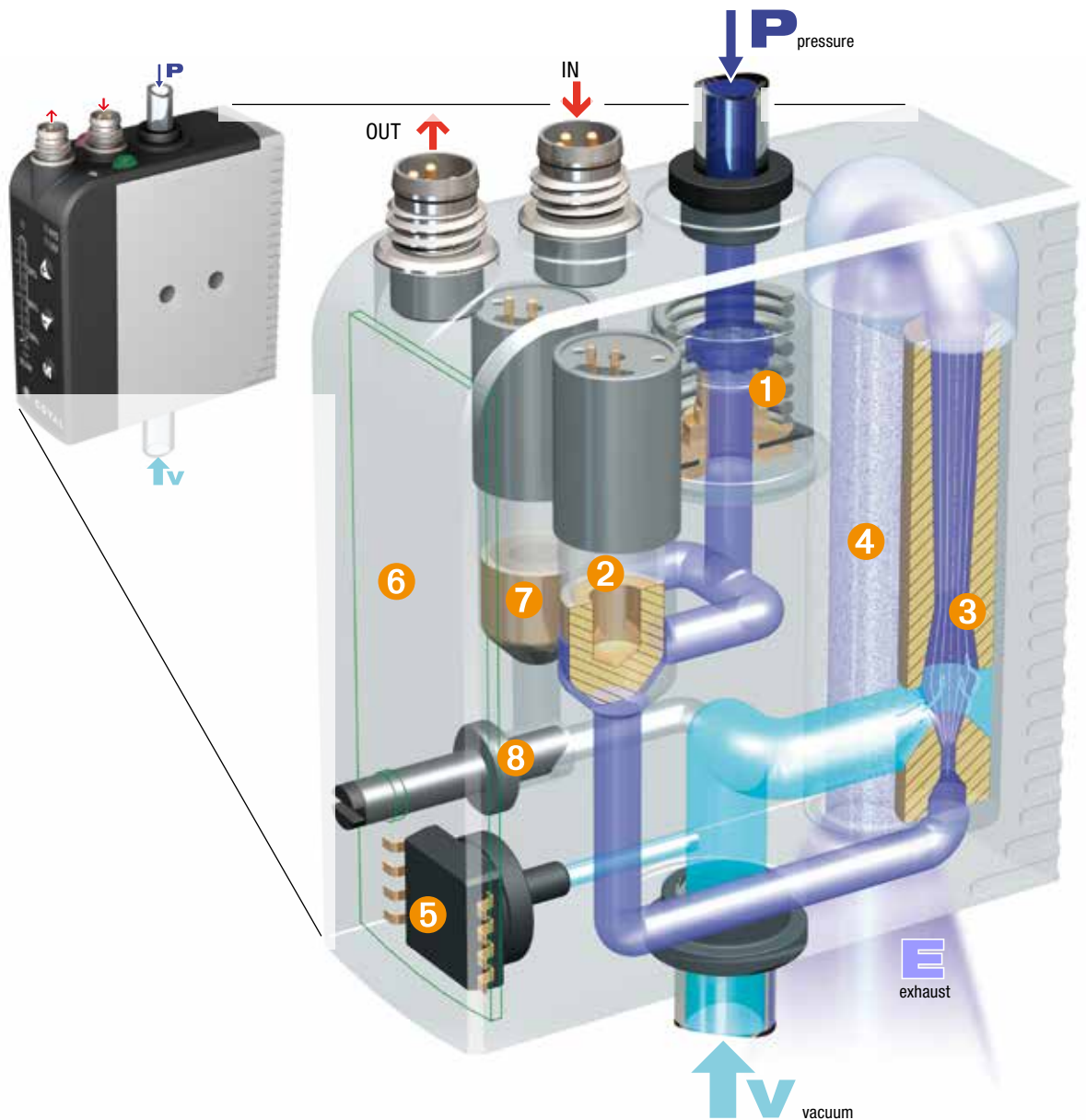

The COVAL Compact Integration Technique

Traditional venturi vacuum pumps must be completed with optional components necessary to function: solenoid valves, pressure regulator, vacuum switch, blow-off circuit, electronic control, etc.

One can see the advantages of compact integration of these functions into a sole mini-module vacuum pump that becomes all inclusive. The above illustration shows the excellence of Coval in this perspective: each function type to be integrated has been redesigned, optimized and miniaturized to fit its place in the mini-module body.

ADVANTAGES

- **direct control 24 V DC - 0.7W**
- M8 connectors, IP65 protection.

• **simplified use**

- only one easy to install module;
- instant pneumatic and vacuum connections;
- plug and play.

• **a LEM for each application**

- choice of vacuum level and amount of vacuum flow;
- only necessary functions are retained.

INTEGRATED FUNCTIONS

- 1 3.5 bar Pressure regulator
- 2 Solenoid valve "vacuum"
- 3 3.5 bar optimized Venturi
- 4 Clog-free silencer
- 5 Electronic vacuum switch
- 6 Integrated electronics
- 7 Solenoid valve "blow-off"
- 8 Blow-off flow adjustment

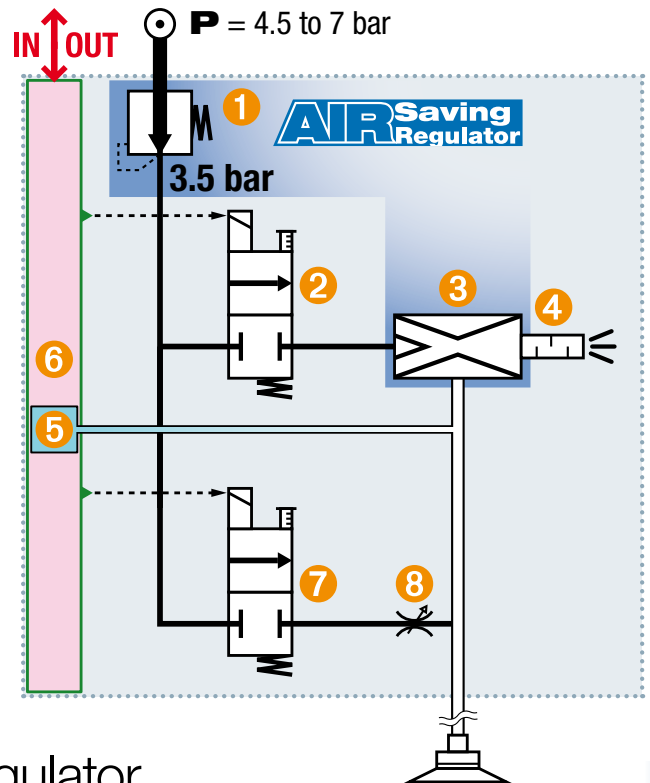

AR Saving Regulator (ASR) Air Saving Regulator Optimized "Regulator+Venturi" Combination

The LEM vacuum pumps, which integrate an ASR "venturi regulator" combination, maintain ideals that COVAL values greatly: reducing both compressed air consumption and noise generation.

Regardless of pressure supplied by the compressed air network, the integrated regulator feeds the venturi at 3.5 bar pressure, optimal for its operation.

- No more unnecessary energy consumption.
- No external regulator required and thus the risk of inadvertent misadjustment is eliminated.
- a remarkably silent operation.

Compared to pressures found in most compressed air networks (5-7 bar), the graph below demonstrates an achieved economy of 40% on average.

ENERGY SAVINGS

- The internal intelligence of the LEM modules controls the network supply pressure and helps to optimize the air consumption to 3.5 bar. This results in exceptional energy savings as shown in the figure below:

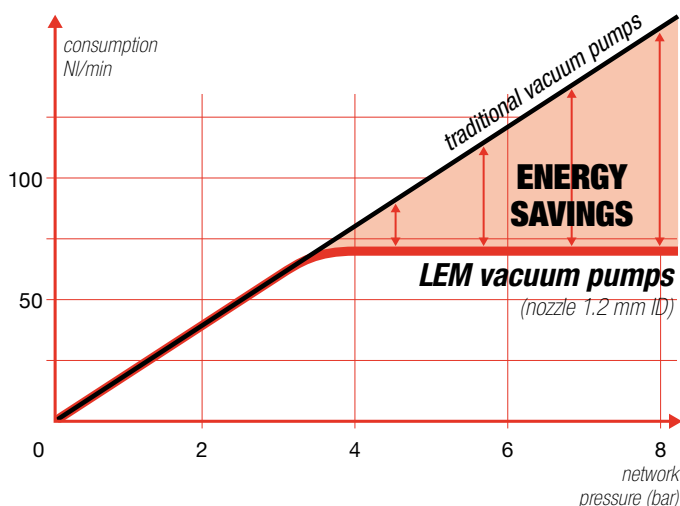

SILENT TECHNOLOGY

- The pressures to be exhausted to atmosphere are much lower.
- The efficiency of the optimized muffler is better.

From this, results the sound level reduction shown by the bar graph below:

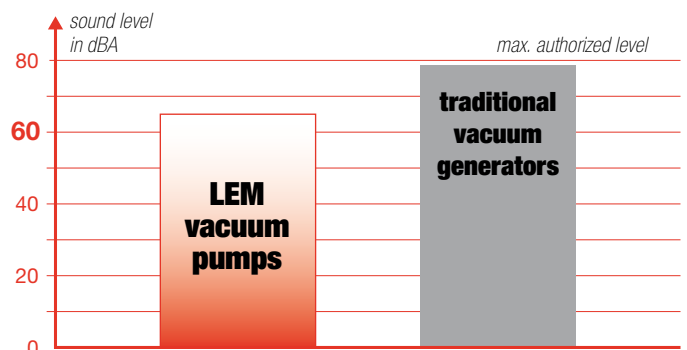

LEM Series: Dialog Intelligence

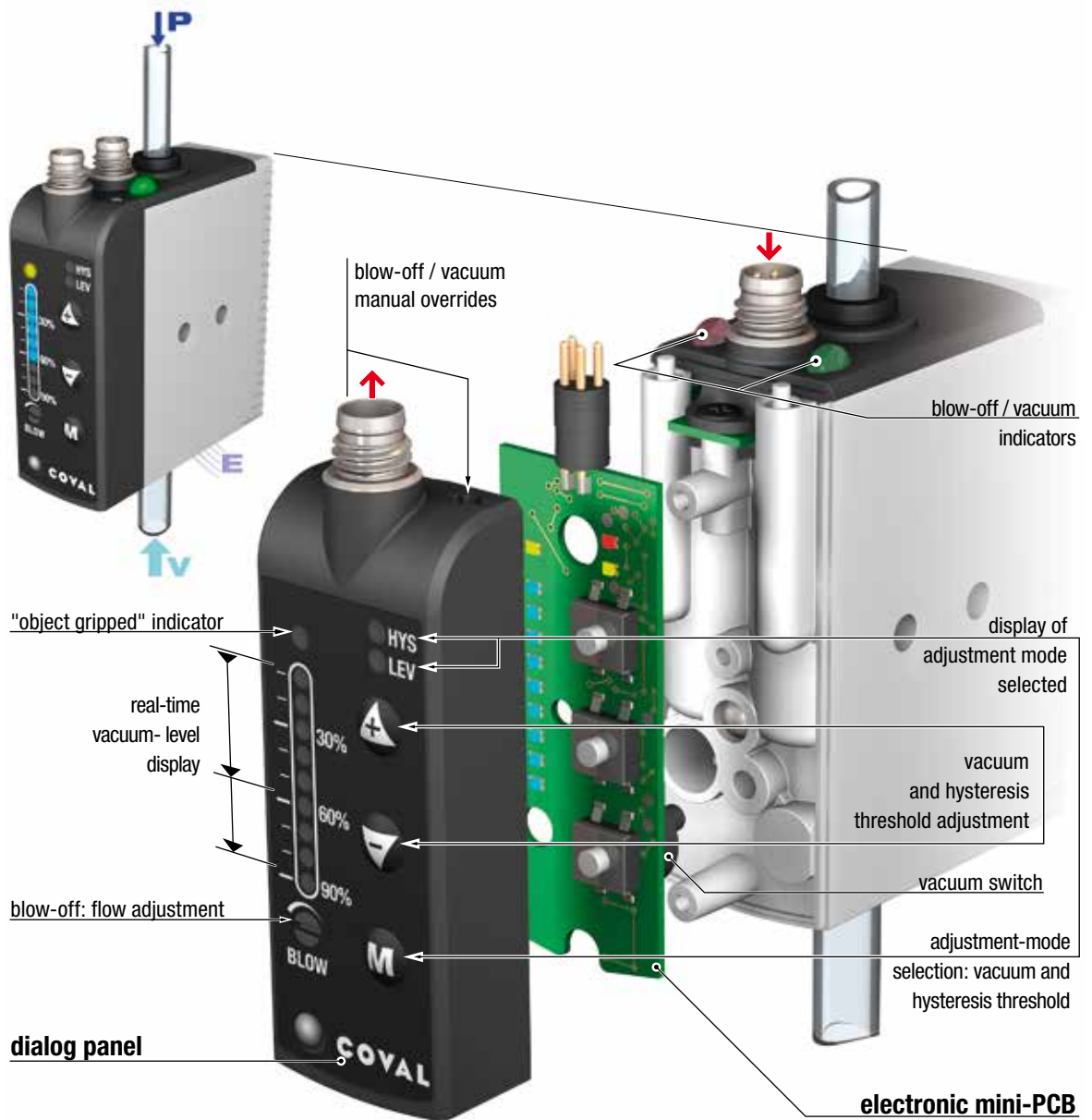

Intelligent Dialog Completes the Integration of Compact Functions

The previous pages have shown the attraction of integrating all necessary functions into a single compact module for optimal control of vacuum handling.

This integration also allows for a compact realization of the intelligent electronics shown above:

- an electronic mini-PCB combines the vacuum switch and other electronic components required for controls and settings.
- a dialog panel completes this by directly controlling the PCB.

ADVANTAGES

• simple and complete communication

For settings and troubleshooting, the dialog panel gathers all information and data required for a complete man/machine interaction, facilitating the machine installation, production and maintenance.

• easy installation, protected equipment

- only one module to mount and to connect.
- sealed M8 connections; IP65 electrical protection;
- lockable dialog panel: protection against unexpected actions.

Efficient Communication at Each Step

1-SETTINGS

Settings are easily made at both the first installation and all successive iterations.

- **Setting of the Vacuum threshold:** the vacuum level at which the vacuum switch emits the "object gripped" signal. Visual display of this setting can be observed on the LED Scale.
- **Hysteresis setting:** the reduction in the vacuum level at which the "object gripped" signal is turned off.
- **Blow-off flow rate setting:** adjustable blow-off control through screw setting or manual valve override while testing.

2-PRODUCTION

Visual surveillance of functioning during each phase: rest, vacuum, blow-off.

- **vacuum:** - "vacuum" activated.
- "vacuum" indicator (green) ON.
- linear LED scale displays the vacuum level.
- at set threshold, "gripped object" indicator and "gripped object" output signal.
- **blow-off:** - "blow-off" is emitted.
- "blow-off" indicator (red) ON.
- the object is released.
- **rest:** no activation signal and no display.

3-TROUBLESHOOTING

After any malfunctioning, troubleshooting is quickly made.

- **Automatic check**
At each return to operation, automatic check of the electronic functions: vacuum switch, displays, settings ...

SETTING
vacuum threshold

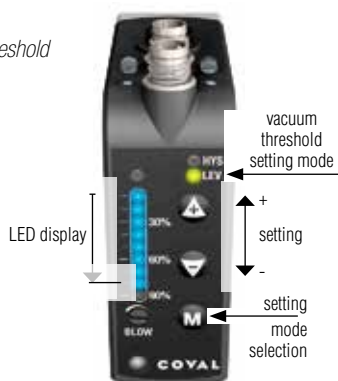

TROUBLESHOOTING
automatic check



Stand-Alone or Island Modules?

Stand-alone modules are suitable for the most common applications; one module controls one or more suction cups which all operate according to the same sequence.

When several suction cups are operating according to different sequences, multiple modules are required, which can be:

- several stand-alone modules, OR
- an island of these modules with an internal common pressure unit.

The adjacent illustrations help in the selection:

- Stand-alone modules are complete, with the integrated pressure regulator.
- In an island, the integrated regulator is absent: to maintain the advantage of economical and silent operation, it is recommended to reduce the pressure to the island's common pressure unit to 4 bar.

Network pressure
4.5 to 7 bar

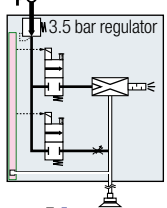

Network pressure 4 bar
common pressure unit

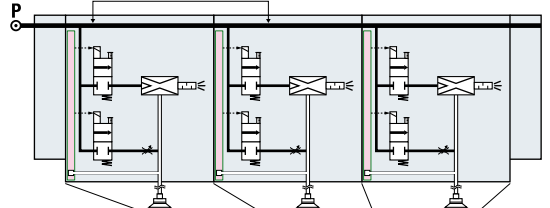

P optimal = 4 bar
(operation at 4-7 bar)



island of
3 modules supplying
suction pads according
to different sequences

CHARACTERISTICS AND CONNECTING AN ISLAND

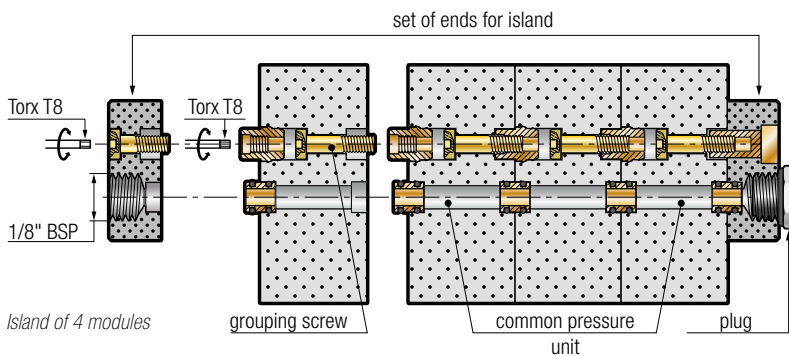

Maximum number of modules in an island:

- Ø 1.4 mm nozzle → 5 modules.
- Ø 1.2 mm nozzle → 7 modules.
- Ø 1.0 mm nozzle → 9 modules..

Note: in the same island, it is possible to combine LEM series modules and LEMAX series modules.

REF. COMPOSED OF AN ASSEMBLED ISLAND OR COMPONENTS FOR

REF. COMPOSED OF A STAND-ALONE MODULE

LEM

90

X

12

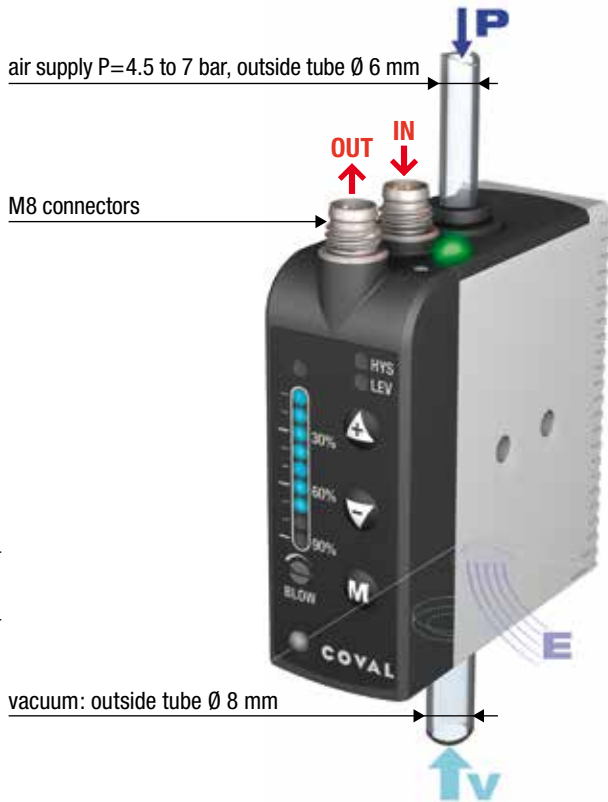

VACUUM LEVEL		NOZZLE DIAMETER	
85% max. vacuum optimum for airtight products	90	10	Ø1 mm nozzle
60% max. vacuum optimum for porous products	60	12	Ø1.2 mm nozzle
		14	Ø1.4 mm nozzle

VENTURI CHARACTERISTICS

1- Maximum vacuum level

This level results from the venturi mixer's profile:

- 85% max. vacuum is optimum for airtight products.
- 60% max. vacuum is optimum for porous products.

2- Nozzle diameter

It reflects the air suction flow, but also the power consumption. Thus it must be chosen for the specific need, without excess.

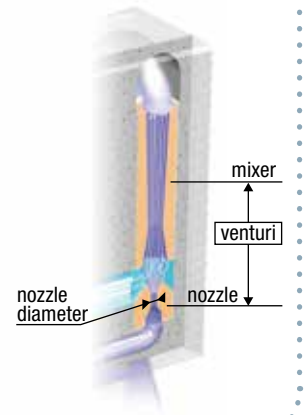

Airtight products handling: glass, plastic, coated wood, metal sheet ...

Because vacuum leaks are limited, the vacuum level to be used may be high: between 50 to 80%, to be generated by a **85% max. vacuum level venturi.**

Taking into account the volume to be emptied and the response time to do so, the chart below is a guide towards the most economical nozzle and gives the air suction flow.

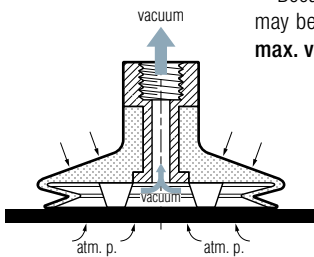

85% max. vacuum LEM

nozzle ID	Time to create vacuum (seconds) for a volume of 1 liter						Air consumption (NI/min)	Air drawn in (NI/min)
	reached vacuum	55%	60%	65%	70%	75%		
1.0 mm	1.76	2.04	2.38	2.80	3.33	4.09	44	29
1.2 mm	1.13	1.31	1.53	1.80	2.15	2.64	65	45
1.4 mm	0.73	0.85	0.99	1.16	1.38	1.70	90	70

Porous products handling: cardboard, raw wood, pastries ...

Significant porosity and/or surface vacuum leaks are to be expected. For handling, a vacuum level between 30 to 55% is the best compromise, to be generated by a **60% max. vacuum level venturi.**

The chart below is a first indication towards the most economical nozzle ID, to be completed by a product leak flow measurement.

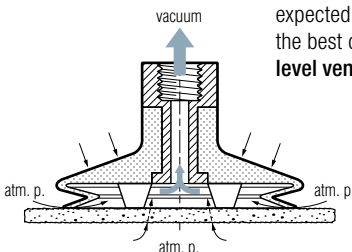

60% max. vacuum LEM

nozzle ID	Time to create vacuum (seconds) for a volume of 1 liter						Air consumption (NI/min)	Air drawn in (NI/min)
	reached vacuum	30%	35%	40%	45%	50%		
1.0 mm	0.66	0.83	1.04	1.31	1.70	2.35	44	38
1.2 mm	0.41	0.52	0.66	0.83	1.07	1.49	65	72
1.4 mm	0.27	0.34	0.43	0.54	0.70	0.97	90	92

AN ISLAND TO BE ASSEMBLED



MODULE COMPOSITION	
R	<p>Simple vacuum pump without blow-off: LEM__X__RV__</p> <ul style="list-style-type: none"> • Only one control signal. • NC vacuum control valve.
S	<p>Vacuum pump with controlled blow-off: LEM__X__SV__</p> <ul style="list-style-type: none"> • 2 control signals. • NC vacuum control valve. • Blow-off controlled by external signal (NC control valve) with adjustable flow rate.
U	<p>Simple vacuum pump without blow-off: LEM__X__UV__</p> <ul style="list-style-type: none"> • Only one control signal. • NO vacuum control valve.
V	<p>Vacuum pump with controlled blow-off: LEM__X__VV__</p> <ul style="list-style-type: none"> • 2 control signals. • NO vacuum control valve. • Blow-off controlled by external signal (NC control valve) with adjustable flow rate.

VACUUM SWITCH / DIALOG PANEL	
VA	<p>Electronic vacuum switch with display and setting</p> <ul style="list-style-type: none"> • Separate settings for vacuum threshold and hysteresis. • Real-time vacuum level display. • "Gripped product" indicator. • M8 connectors for inputs and outputs. Switching output and analogic output. • Electrical protection: IP65.
VO	<p>No vacuum switch</p> <ul style="list-style-type: none"> • Automatic functioning up to maximum vacuum level (no setting and no display). • M8 connector for inputs only. • Electrical protection: IP65.

ISLAND ASSEMBLIES	
B2	<p>LEM__X__B2 island assembly with 2 identical modules</p>
B3	<p>LEM__X__B3 island assembly with 3 identical modules</p>
B4	...

If the planned island contains different module types, it must be delivered as separate components in order to then be assembled on site according to the arrangement suitable to the application.

COMPONENTS FOR THE ISLAND TO BE ASSEMBLED	
B	<p>LEM__X__B Module that can be grouped (complete with integrated grouping screw).</p>
	<p>Set of endplates for a complete group, with grouping screw and common pressure unit plug.</p> <p>REF: LEMSETA</p>

EXAMPLE COMPOSITE PART NUMBER FOR AN ISLAND ASSEMBLY:

- LEM60X14SVAB3

LEM island assembly, containing 3 x 60% max. vacuum modules, ø 1.4 mm nozzle, controlled by NC solenoid valve, blow-off and vacuum switch.

ORDER EXAMPLE FOR AN ISLAND TO BE ASSEMBLED:

- LEM60X10VVAB
- LEM90X12SVAB
- LEM60X14SVAB

3 LEM modules for a group, of different types.

- LEMSETA → Set of endplates for island.

REFERENCE EXAMPLE COMPOSED OF A STAND-ALONE MODULE:

- LEM60X12SVA

Stand-alone LEM Module, 60% max. vacuum, ø 1.2 mm nozzle, vacuum controlled by NC solenoid valve, blow-off along with vacuum switch.

LEM Series: Mounting Options

1- Stand-alone modules

SIDE MOUNTING

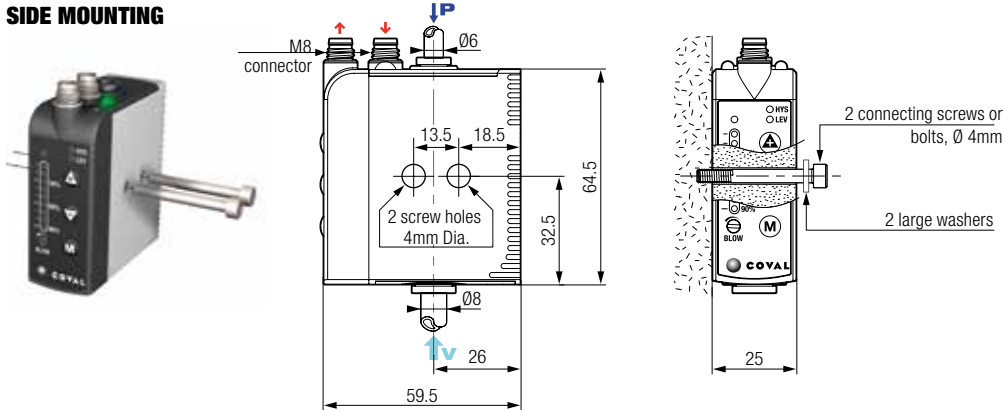

The side mounting is the simplest of all: 2 protruding screws.

FRONT MOUNTING

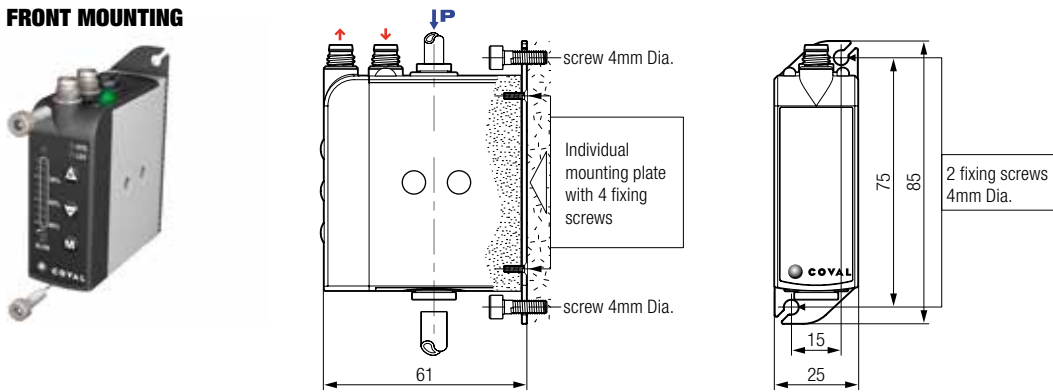

For mounting from front, please order the necessary kit in addition to the ejector module:

Kit for mounting from front :
1 plate + 4 screws
Part No.: LEMFIXA

MOUNTING ON DIN RAIL

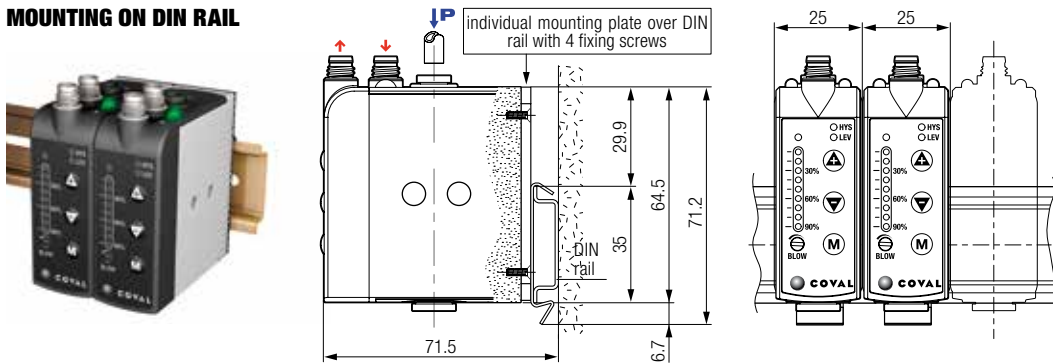

A module can be clipped onto a DIN rail.

For this purpose, the module must first be equipped with an individual DIN installation plate, ordered separately:

DIN rail mounting kit:
1 plate/clip + 4 screws
Part No.: LEMFIXB

2- Islands

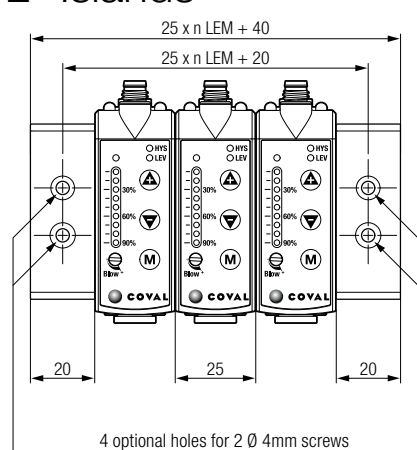

FRONT MOUNTING

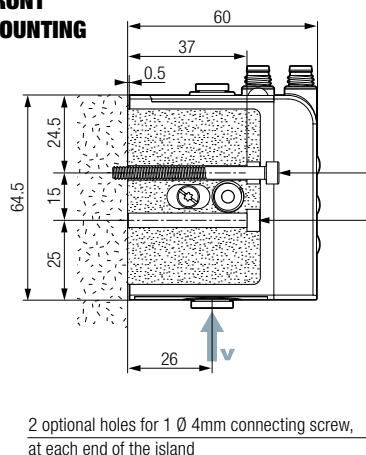

MOUNTING ON DIN RAIL

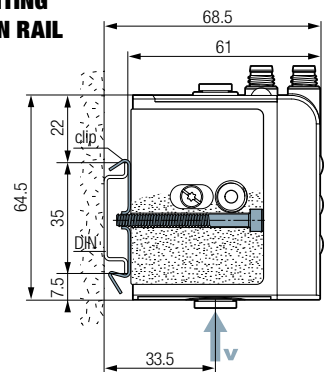

DIN rail mounting kit:
2 clips + 2 screws
Part No.: LEMFIXC

LEM Series: Characteristics

General Characteristics

- C.A supply 5µ filtered, non-lubricated air relevant to ISO 8573-1 class 4 standard.
- Optimal working pressure: 4.5 to 7 bar.
- Mini dynamic pressure:
 - stand-alone module: P = 4.5 bar.
 - island modules: 4 bar.
- Blow-off: adjustable flow:
 - stand-alone version: P = 3.5 bar.
 - island version: P network.
- Maximum vacuum: 60% or 85% according to model (see page 8).
- Suction flow rate: 29 to 92 NL/min according to model (see page 8).
- Air consumption: from 44 to 90 NL/min according to model (see page 8).
- Electric degree of protection: IP65.
- Voltage tension: 24 V DC (adjustable ± 10%).
- Current draw: 30 mA (0,7W) vacuum or blow-off.
- Maximum frequency of utilization: 4 Hz.
- Number of operations: 30 million cycles.
- Weight: from 80 to 120 g according to model.
- Operating temperature: from 10 to 60 °C or 50 to 140°F.
- Materials: PA 6-6 15% FG, brass, aluminum, NBR.

Electrical Connections

MODULES WITHOUT VACUUM SWITCH

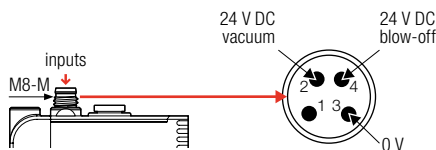

MODULES WITH VACUUM SWITCH

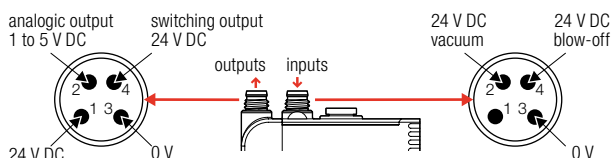

Integrated Vacuum Switch

- Adjusting range: -1 to 0 bar.
- Precision: ± 1, 5 % of the range.
- Hysteresis: from 0% to 100% (adjusted by potentiometer).
- Output threshold: 1 x switching output, NO.
- Analogic output: from 1 V DC over the measuring range.
- Switching power: 125 mA PNP.
- Threshold state display : 1x LED green
- Power supply: 24 V DC (regulated ± 10%)
- Current draw: < 20 mA.
- Protection: against the inversions of polarity.

Integrated Silencer

- Sound level: approximately 68 dBA.
- Clog free silencer.

Suction Flow Rate/Vacuum Curves

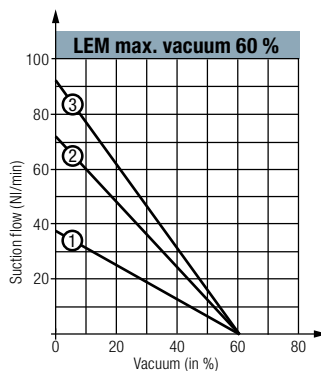

- 1- LEM60X10
- 2- LEM60X12
- 3- LEM60X14

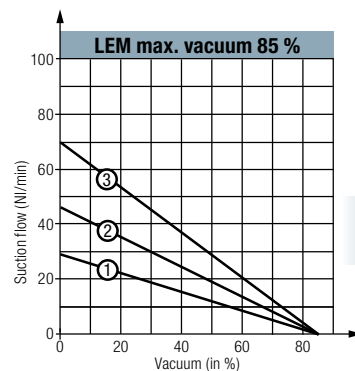

- 1- LEM90X10
- 2- LEM90X12
- 3- LEM90X14

LEMAX: Complementary Series

LEMAX series

- **Series convenient for all airtight product gripping:**
 - The ASC mechanism saves 60 to 99% energy automatically.

The common advantages

- **Integration:** all necessary functions are integrated into a complete mini-module.
- **Intelligence:** integrated electronics for configuring the application and automatic follow-up.
- **Complete ranges to suit all applications:**
 - Power choice: Ø 1mm, 1.2mm and 1.4 mm nozzle.
 - Installations with choice of:
 - stand-alone modules.
 - island modules.



Island gathering LEM modules and LEMAX modules



COVAL
vacuum managers

vacuum components



A TECHNOLOGICAL PARTNER ON A GLOBAL SCALE

Located in the southeast region of France, COVAL conceives, manufactures and globally distributes high performance, advanced vacuum automation components and systems for industrial applications in all branches.

COVAL is an ISO 9001: V2015 certified company which offers innovative solutions integrating reliable and optimized components with intelligent functionalities. The focus is to provide the most personalized and economic solution to a given application while assuring a significant improvement in the productivity and the safety for the vacuum users around the world.

COVAL has an ambition for technical excellence and innovation. As a specialist in vacuum automation, COVAL is reputed for offering reliable, personalized, cost effective and productive solutions.

The references of COVAL can be found in several industrial sectors (Packaging, Automotive Industry, Plastic, Graphic, Aeronautic...) where vacuum handling is important for high efficiency and productivity.

COVAL markets its products and services all over Europe, in the United States and South America through its subsidiaries and authorized distribution network. COVAL strives to provide customer driven solutions and gives the best possible treatment to satisfy all its clients.

For all enquiries from Australia, Africa and Asia kindly contact COVAL head office in France.

Distributed by:



certified quality
management system

COVAL S.A.S.
Head Office
ZA des Petits Champs
26120 Montélier France
Tel : +33 (0)4 75 59 91 91
Fax : +33 (0)4 75 59 91 05

www.coval.com